



Fagor Automation S. Coop.

**ENCODER LINEAL MODELO: G2**  
***LINEAR ENCODER MODEL: G2***

**MANUAL DE INSTALACION / *INSTALLATION MANUAL***

Manual Code: 14460209

Manual Version: 1612





## Precaución / Caution

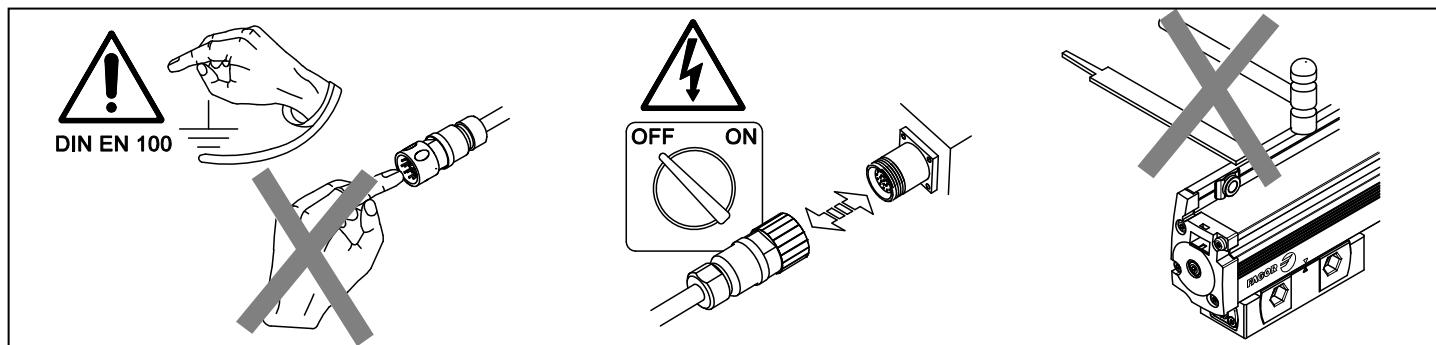

## Dimensiones / Dimensions

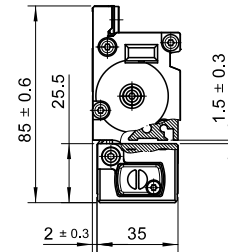
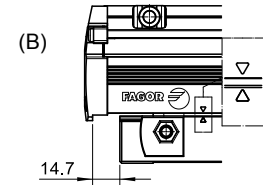
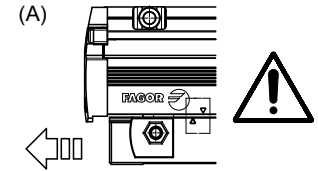
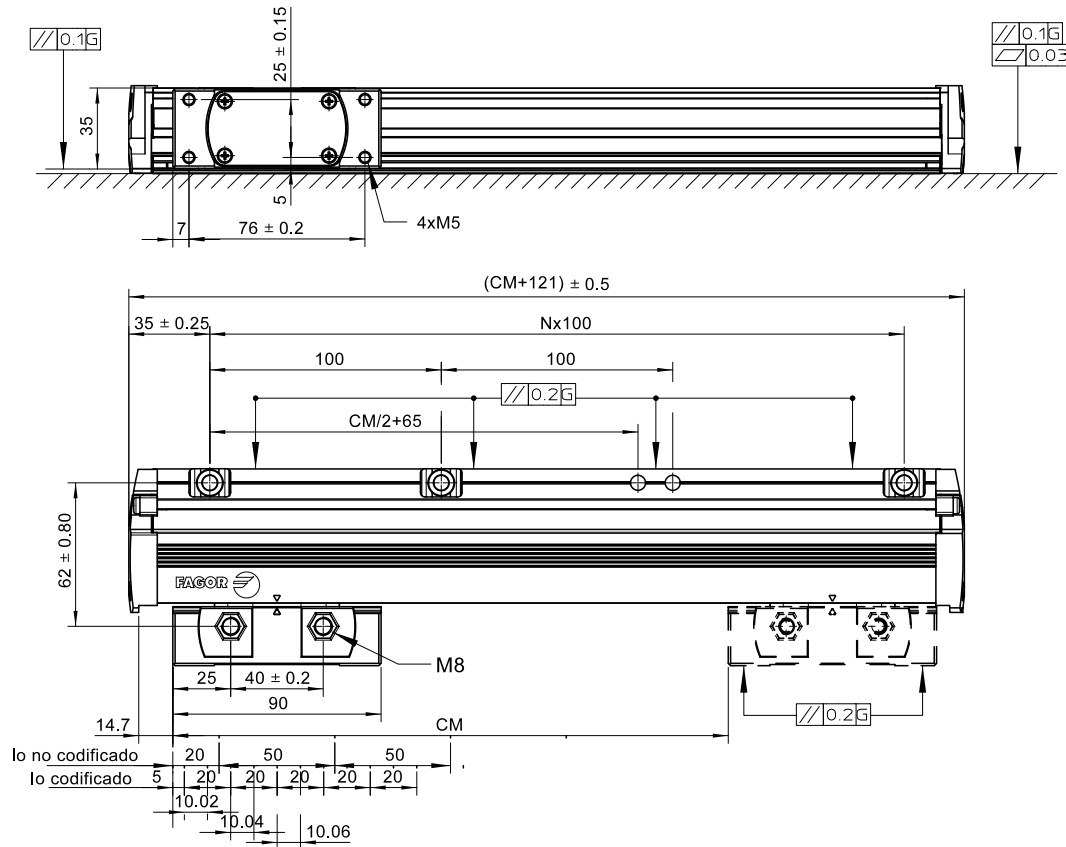

mm  
Tolerancing ISO 8015  
ISO 2768 - m H  
< 6 mm:  $\pm 0.2$  mm

(A) no golpear la cabeza contra los extremos de la regla / do not run the head into the ends of the scale

(B) marcas alineadas = comienzo de CM / aligned marks = beginning of measuring length

G = Guía máquina / Machine guideway

## Posibilidades de montaje / Mounting possibilities

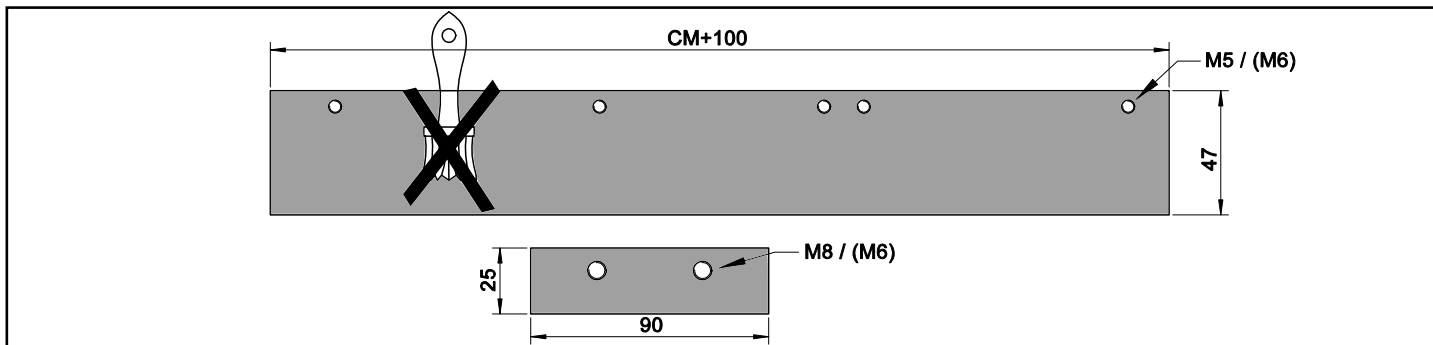

Realizar los agujeros para amarrar la regla.  
El área sobreada debe estar libre de pintura.

*Make the holes to secure the scale.  
The shaded area must be free of paint.*

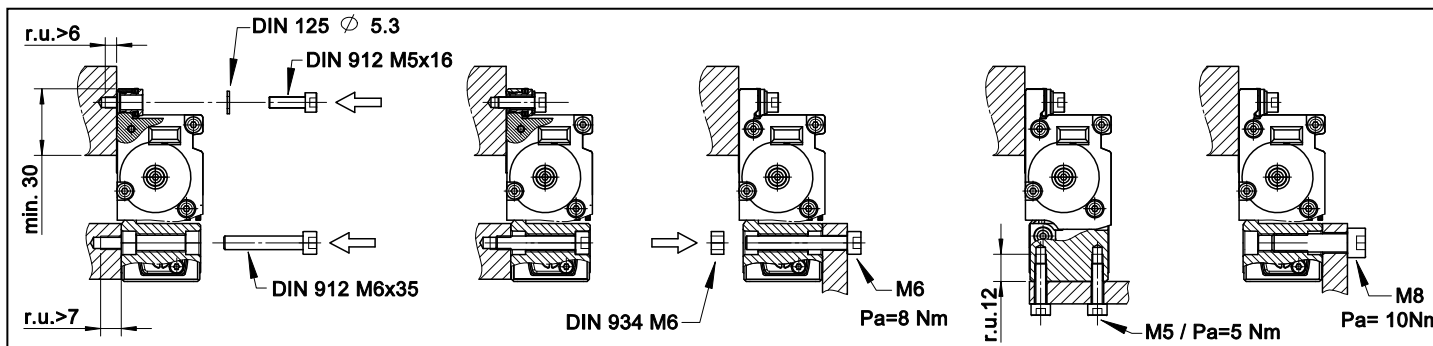

Opciones de montaje de la regla.  
r.u. = rosca útil  
Pa = par de apriete

*Scale mounting possibilities  
r.u. = useful thread  
Pa = tightening torque*

## Opción cabeza con rosca M6 / M6 Threaded head option

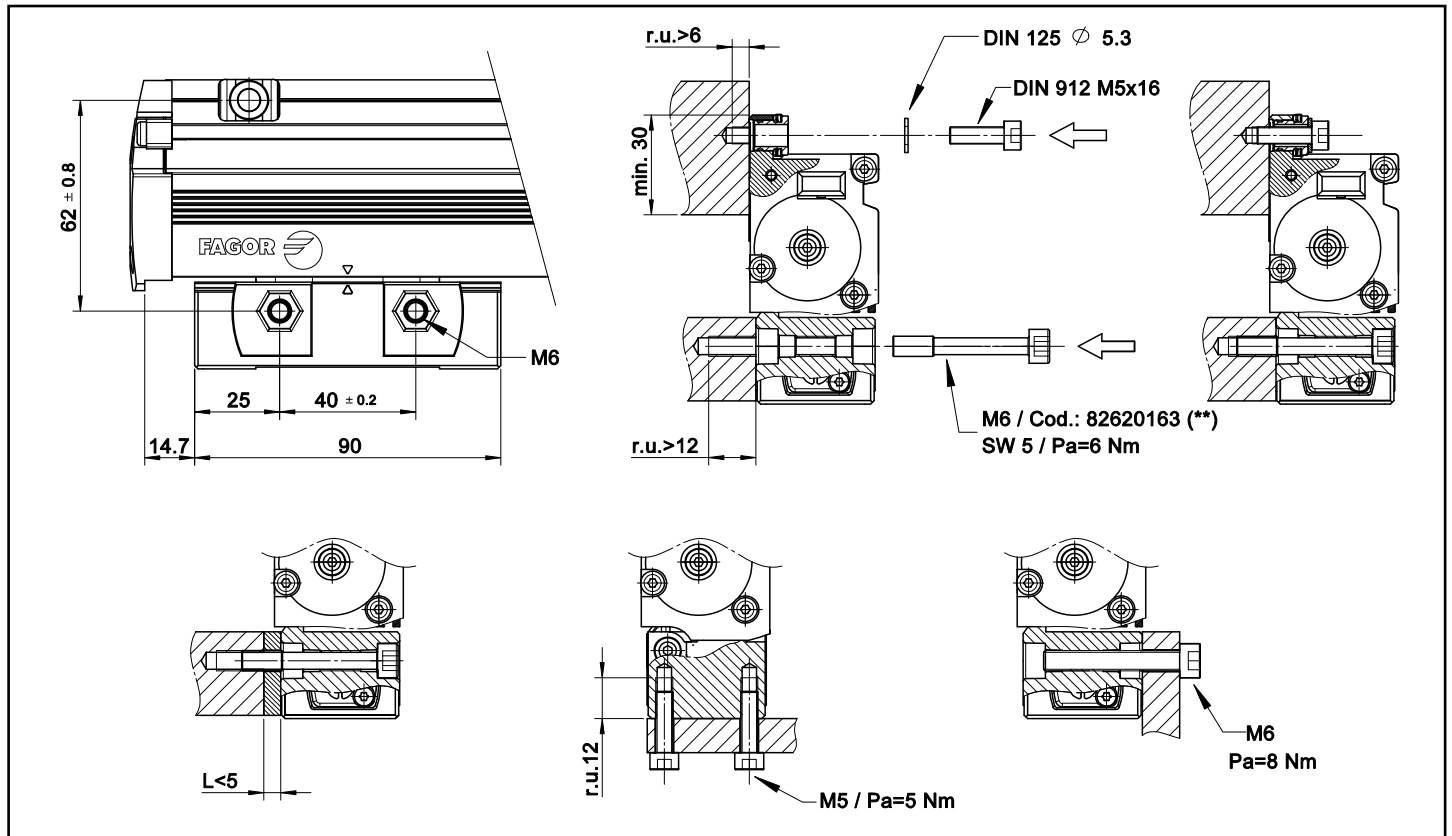

(\*\*) Material exclusivo suministrado por Fagor. Código indicado para realizar pedido de unidades adicionales  
*Exclusive material supplied by Fagor. Code shown for ordering additional units.*

(SW) Tamaño de la llave hexagonal / Size of Allen wrench

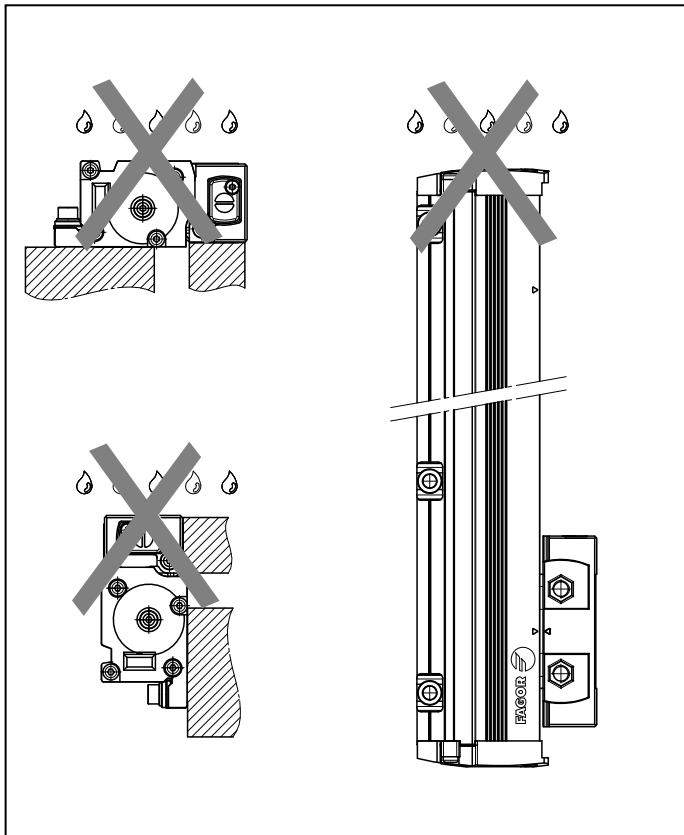

Evitar orientar los labios de estanqueidad a la exposición de posibles fuentes de contaminación  
 Avoid orienting the sealing lips towards pollution sources

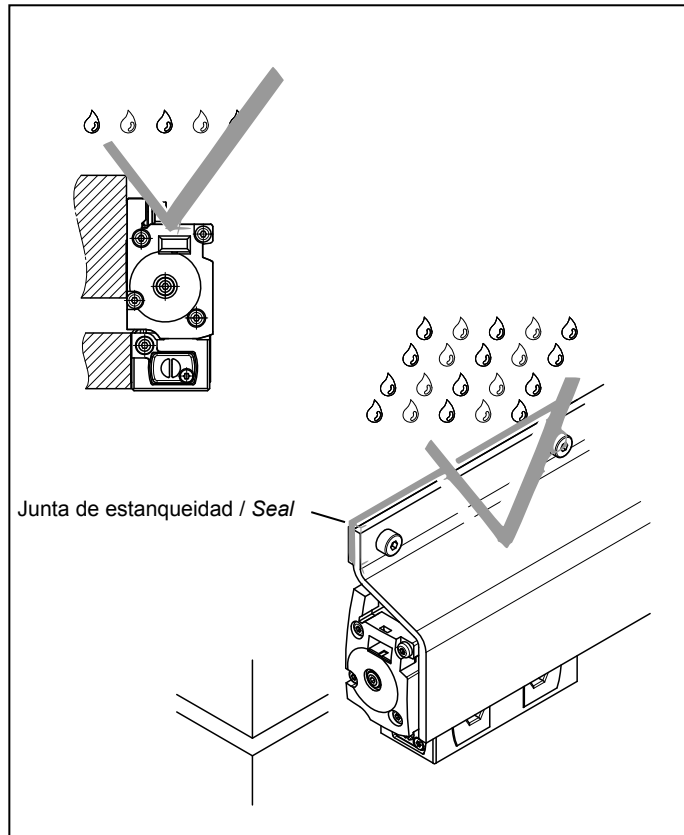

En ambientes muy contaminantes, conviene proteger la regla.  
 Utilizar juntas de estanqueidad para evitar filtraciones  
 In very polluted environments, the scale should be protected.  
 Use seals to prevent filtrations.

## Posibilidades de montaje, tolerancias / Mounting possibilities, tolerances

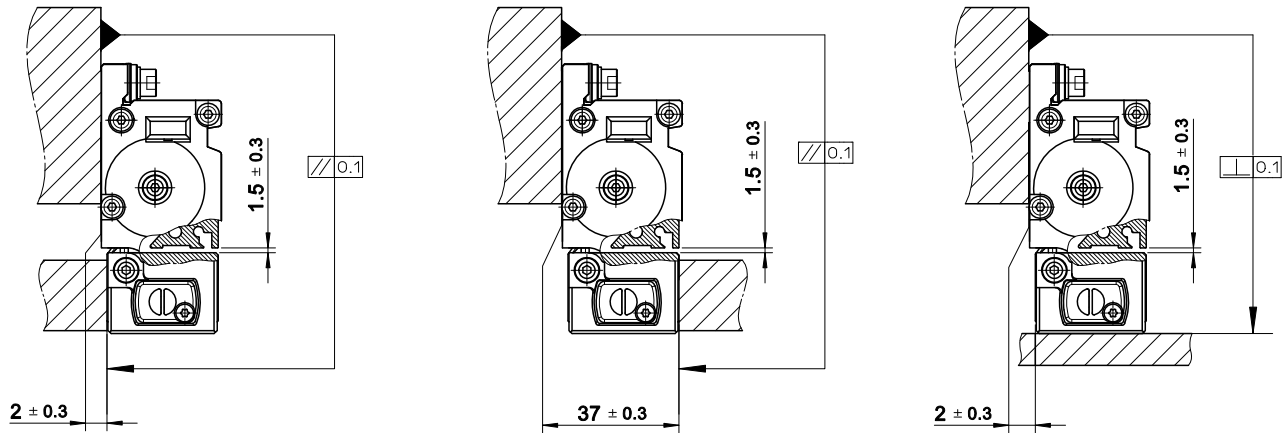



Montaje sobre tope máquina  
*Mounting against the machine*

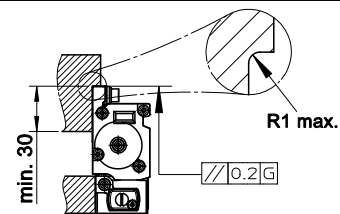

Montaje sobre pasadores  
*Mounting on dowel pins*

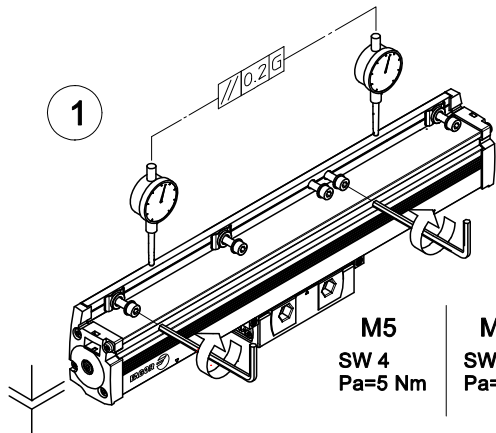
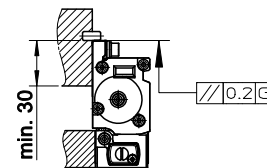

**M5**  
SW 4  
Pa=5 Nm

**M6**  
SW 5  
Pa=8 Nm

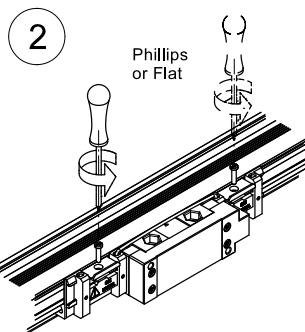

Phillips  
or Flat

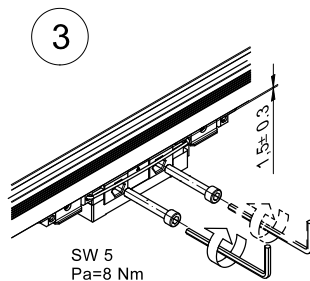

SW 5  
Pa=8 Nm

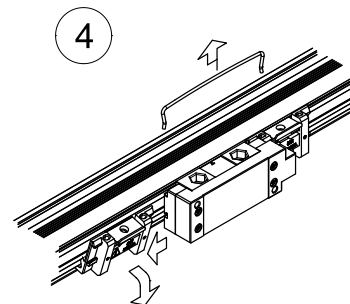

1. Premontar y alinear la regla. Una vez alineada, apretar los tornillos.
2. Quitar los tornillos de las piezas de embalaje y posicionar la cabeza.
3. Meter los tornillos de la cabeza y apretar.
4. Quitar las piezas de embalaje de la cabeza.

1. Premount and align the scale. Once aligned, fasten the screws.
2. Remove the screws of the packing parts and position the reader head.
3. Insert the head screws and fasten them.
4. Remove the packing parts of the reader head.

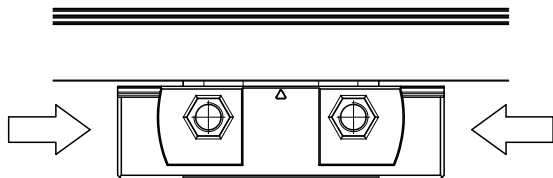

**CONECTOR A AMBOS LADOS / CONNECTOR AT BOTH ENDS**

Nota: Sólo conectar a un lado / Note: Only connect at one end

Para hacer la conexión: / To connect:

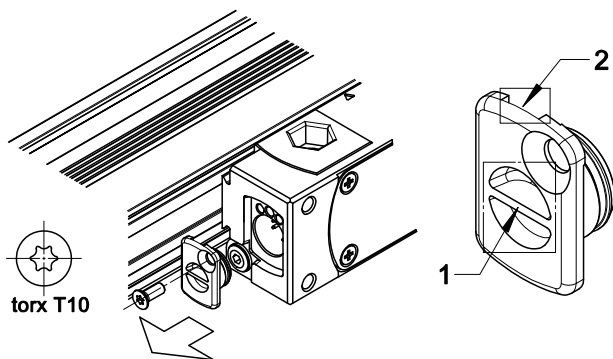

Soltar el tornillo y quitar la tapa del lado del conector  
Loosen the bolt and remove the lid of the connector side

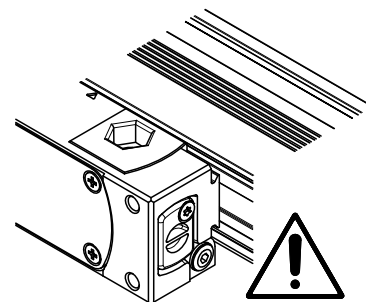

No quitar la tapa del lado no conector  
Do not remove the lid of the non-connector side

Unidades de filtro de aire Fagor  
Fagor air filter units

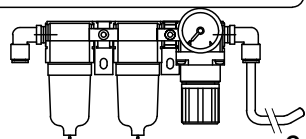

Pa = 1 Nm  
SW 8



Cod.: 82620172 (\*)

Para IP-64 For IP-64

1 bar / 14.5 psl / 0.1 MPa  
10 l/min  
Calidad aire: clase 1.4.1.  
Air quality: class 1.4.1.  
ISO 8573-1

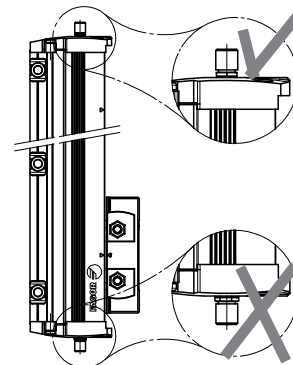
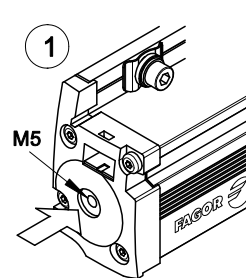

En montajes verticales no meter el aire por abajo  
When mounting vertically, do not feed air from underneath

2

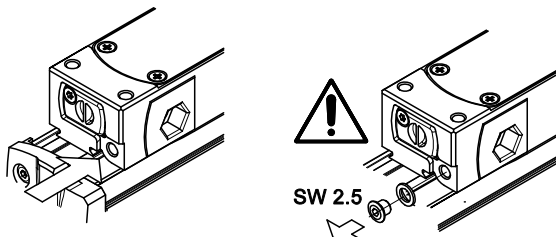
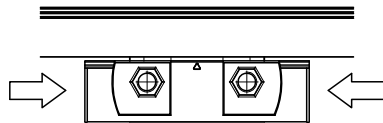

Extraer únicamente el tornillo del lado donde se va a meter el aire  
Remove only the screw at the side of the air intake

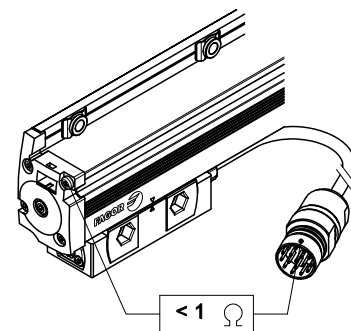
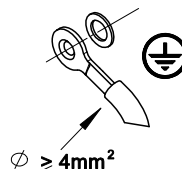

1. Entrada de aire por los tapas; posible por ambos tacos. / Air intake through endcaps; possible through both endcaps.
2. Entrada de aire por la cabeza; doble entrada de aire / Air intake through the reader head; dual air intake

(\*) Material exclusivo suministrado por Fagor. Código indicado para realizar pedido de unidades adicionales  
Exclusive material supplied by Fagor. Code shown for ordering additional units.

## Características eléctricas / *Electrical characteristics*

	G2X	G2Y	G2W	G2Z	G2P
Alimentación <i>Power supply</i>	5 V ± 5%, < 150 mA (sin carga / without load)				5 V ± 10%, < 150 mA (sin carga / without load)
Período señal incremental <i>Incremental signal period</i>	4 µm	2 µm	0.4 µm	0.2 µm	20 µm
Resolución <i>Resolution</i>	1 µm	0.5 µm	0.1 µm	0.05 µm	Hasta / up to 0.1 µm
Longitud de cable <i>Cable length</i>	50 m 164 ft				150 m 492 ft
Radio de curvatura / <i>Bending radius</i>					
	Rígido / <i>Rigid</i>		Flexible		
Φ 6 mm	>24 mm		> 60 mm		
Φ 10 mm (con protección) <i>(with protection)</i>	> 35 mm		> 60 mm		
Φ 8 mm	> 50 mm		> 64 mm		

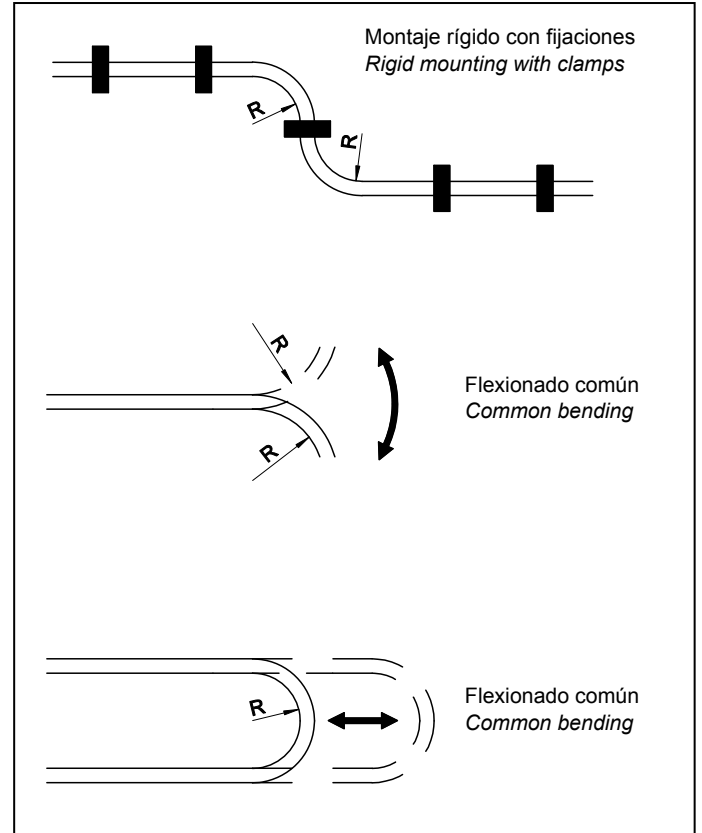

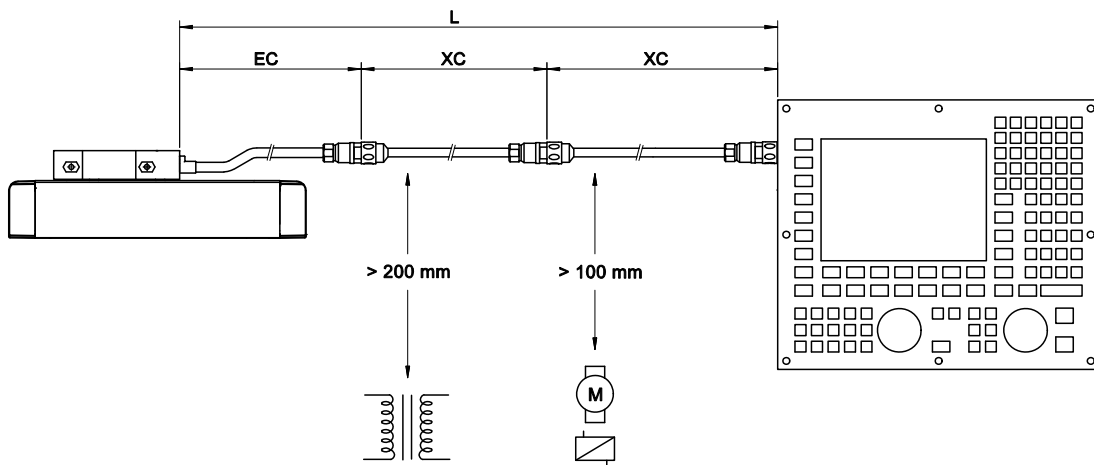

## Cables para conexión de encoders incrementales Fagor Cables for connection of Fagor incremental encoders

### Sistemas Fagor / Fagor systems

Conexión directa Cable EC

*Direct connection EC cable*

EC-P-D Longitud / length = 1, 3, 6, 9, 12 m

Conexión con alargadera

*Connection with extension cable*

(4 x 2 x 0.14 mm<sup>2</sup> + 4 x 0.5 mm<sup>2</sup>)

Cable EC

Alargadera intermedia opcional XCint

*Intermediate extension cable optional XCint*

Alargadera XC / Extension cable XC

EC-A-C1 Longitud / length = 1, 3 m

XC-C2-C1 Longitud / length = 5, 10, 15, 20, 25 m

XC-C2-D Longitud / length = 5, 10, 15, 20, 25 m

### Sistemas Fanuc / Fanuc systems

Conexión directa Cable EC

*Direct connection EC cable*

EC-C-FN1 Longitud / length = 1, 3, 6, 9, 12 m

Conexión con alargadera

*Connection with extension cable*

(4 x 2 x 0.14 mm<sup>2</sup> + 4 x 0.5 mm<sup>2</sup>)

Cable EC

Alargadera intermedia opcional XCint

*Intermediate extension cable optional XCint*

Alargadera XC / Extension cable XC

EC-A-C1 Longitud / length = 1, 3 m

XC-C2-C1 Longitud / length = 5, 10, 15, 20, 25 m

XC-C2-FN1 Longitud / length = 5, 10, 15, 20, 25 m

## Sistemas Panasonic MINAS / Panasonic MINAS systems

Conexión directa Cable EC

*Direct connection EC cable*

EC-C-PN6 Longitud / *length* = 1, 3, 6, 9, 12 m

Conexión con alargadera

*Connection with extension cable*

(5 x 2 x 0.14 mm<sup>2</sup>)

Cable EC

Alargadera intermedia opcional XCint  
*Intermediate extension cable optional XCint*

Alargadera XC / *Extension cable XC*

EC-A-C1 Longitud / *length* = 1, 3 m

XC-C2-C1 Longitud / *length* = 5, 10, 15, 20, 25 m

XC-C2-A-PN6 Longitud / *length* = 5, 10, 15, 20, 25 m

## Sistemas Siemens Solution Line / Siemens Solution Line systems

SME 20 sólo 1Vpp / *only 1Vpp*

SMC 20 sólo 1Vpp / *only 1Vpp*

SMC 30 sólo TTL diferencial / *only differential TTL*

Conexión directa Cable EC

*Direct connection EC cable*

SME 20 EC-A-C5 Longitud / *length* = 1, 3, 6, 9, 12 m

SMC 20 EC-P-S3 Longitud / *length* = 1, 3, 6, 9, 12 m

SMC 30 EC-P-S2 Longitud / *length* = 1, 3, 6, 9, 12 m

Conexión con alargadera

*Connection with extension cable*

(4 x 2 x 0.14 mm<sup>2</sup> + 4 x 0.5 mm<sup>2</sup>)

Cable EC

Alargadera intermedia opcional Xcint  
*Intermediate extension cable optional Xcint*

Alargadera XC / *Extension cable XC*

SME 20 EC-A-C5 Longitud / *length* = 1, 3 m

XC-C4-C5 Longitud / *length* = 5, 10, 15, 20, 25 m

XC-C4-C5 Longitud / *length* = 5, 10, 15, 20, 25 m

SMC 20 EC-A-C5 Longitud / *length* = 1, 3 m

XC-C4-C5 Longitud / *length* = 5, 10, 15, 20, 25 m

XC-C4-S3 Longitud / *length* = 5, 10, 15, 20, 25 m

SMC 30 EC-A-C5 Longitud / *length* = 1, 3 m

XC-C4-C5 Longitud / *length* = 5, 10, 15, 20, 25 m

XC-C4-S2 Longitud / *length* = 5, 10, 15, 20, 25 m

## Otros sistemas (sin conector terminal) / Other systems (without terminal connector)

Conexión directa Cable EC

*Direct connection EC cable*

EC-AS-O Longitud / *length* = 1, 3, 6, 9, 12 m

Conexión con alargadera

*Connection with extension cable*

(4 x 2 x 0.14 mm<sup>2</sup> + 4 x 0.5 mm<sup>2</sup>)

Cable EC

Alargadera intermedia opcional XCint  
*Intermediate extension cable optional XCint*

Alargadera XC / *Extension cable XC*

EC-A-C1 Longitud / *length* = 1, 3 m

XC-C2-C1 Longitud / *length* = 5, 10, 15, 20, 25 m

XC-C2-O Longitud / *length* = 5, 10, 15, 20, 25 m

## Otros sistemas, encoders G2Z (sin conector terminal) Other systems, G2Z encoders (without terminal connector)

Conexión directa Cable EC

*Direct connection EC cable*

EC-C-O Longitud / *length* = 1, 3, 6, 9, 12 m

Conexión con alargadera

*Connection with extension cable*

(4 x 2 x 0.14 mm<sup>2</sup> + 4 x 0.5 mm<sup>2</sup>)

Cable EC

Alargadera intermedia opcional XCint  
*Intermediate extension cable optional XCint*

Alargadera XC / *Extension cable XC*

EC-A-C1 Longitud / *length* = 1, 3 m

XC-C2-C1 Longitud / *length* = 5, 10, 15, 20, 25 m

XC-C2-O Longitud / *length* = 5, 10, 15, 20, 25 m



EC - A - C1 EC - A - C5	Conector circular 12 macho / <i>12-pin male round connector</i>											
PIN	5	6	8	1	3	4	7	12	2	10	11	Carcasa / <i>Housing</i>
SEÑAL SIGNAL	A	/A	B	/B	lo	/lo	/Alarm	+5 V	+5 sensor	0 V	0 V sensor	Tierra / <i>Ground</i>
COLOR	Verde <i>Green</i>	Amarillo <i>Yellow</i>	Azul <i>Blue</i>	Rojo <i>Red</i>	Gris <i>Grey</i>	Rosa <i>Pink</i>	Violeta <i>Purple</i>	Marrón <i>Brown</i>		Blanco <i>White</i>		Malla / <i>Shield</i>

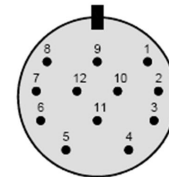
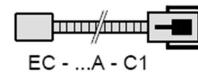

EC - AS - O	Sin conector / <i>Without connector</i>											
SEÑAL SIGNAL	A	/A	B	/B	lo	/lo	+5 V	+5 sensor	0 V	0 V sensor	Tierra / <i>Ground</i>	
COLOR	Verde <i>Green</i>	Amarillo <i>Yellow</i>	Azul <i>Blue</i>	Rojo <i>Red</i>	Gris <i>Grey</i>	Rosa <i>Pink</i>	Marrón <i>Brown</i>	Violeta <i>Purple</i>	Blanco <i>White</i>	Negro <i>Black</i>	Malla / <i>Shield</i>	



EC - C - O	Sin conector / <i>Without connector</i>											
SEÑAL SIGNAL	A	/A	B	/B	lo	/lo	+5 V	0 V	Tierra / <i>Ground</i>		Tierra / <i>Ground</i>	
COLOR	Verde <i>Green</i>	Amarillo <i>Yellow</i>	Azul <i>Blue</i>	Rojo <i>Red</i>	Gris <i>Grey</i>	Rosa <i>Pink</i>	Marrón <i>Brown</i>	Blanco <i>White</i>	Malla interior-Negro <i>Internal shield - Black</i>		Malla exterior <i>External shield</i>	



## Garantía / Warranty

\*Plazo: 12 meses a partir de la fecha de expedición de fábrica.

\*Cubre gastos de Materiales y Mano de Obra de reparación en FAGOR AUTOMATION.

\*Los gastos de desplazamiento son a cargo del cliente.

\*No cubre averías por causas ajenas a FAGOR AUTOMATION, como: golpes, manipulación por personal no autorizado, etc

*\*Term: 12 months from factory invoice date.*

*\*It covers parts and labor at FAGOR AUTOMATION.*

*\*Travel expenses are payable by the customer.*

*\*Damages due to causes external to FAGOR AUTOMATION, such as unauthorized handling, blows, etc. are not covered.*

## Declaración de conformidad / Declaration of conformity

**Fabricante: Fagor Automation, S. Coop.**

Barrio de San Andrés 19, C.P. 20500, Mondragón -Guipúzcoa- (ESPAÑA).

Declaramos bajo nuestra exclusiva responsabilidad la conformidad del producto al que hace referencia este manual

Nota. Algunos caracteres adicionales pueden seguir a las referencias de los modelos indicados en este manual. Todos ellos cumplen con las siguientes normas:

**Compatibilidad electromagnética:**

EN 61000-6-2:2005 Norma de Inmunidad en entornos industriales

EN 61000-6-4:2007 Norma de Emisión en entornos industriales

De acuerdo con las disposiciones de la Directiva Comunitaria: 2014/30/UE de Compatibilidad Electromagnética.

**Manufacturer: Fagor Automation, S. Coop.**

Barrio de San Andrés 19, C.P. 20500, Mondragón -Guipúzcoa- (SPAIN).

We declare under our exclusive responsibility the conformity of the product referred to in this manual.

Note. Some additional characters may follow the model references indicated in this manual. They all comply with the following regulations:

**Electromagnetic compatibility:**

EN 61000-6-2:2005 Standard on immunity in industrial environments

EN 61000-6-4:2007 Standard on emission in industrial environments

According to the European Directive: 2014/30/EU on electromagnetic compatibility.

Mondragón a 1 de diciembre de 2016

Fagor Automation, S. Coop.

Mondragón December 1st, 2016.



Director Gerente  
José Pérez Berdud



FAGOR AUTOMATION S. COOP.

B° San Andrés N° 19

Apdo de correos 144

20500 Arrasate/Mondragón

- Spain -

Web: [www.fagorautomation.com](http://www.fagorautomation.com)

Email: [info@fagorautomation.es](mailto:info@fagorautomation.es)

Tel.: (34) 943 719200

Fax: (34) 943 791712



Fagor Automation